

Euroglobe EGC33-12

Specifications

Nominal Voltage		12V
Rated capacity (20 hour rate)		35Ah
Dimensions	Length	195±2mm(7.68inch)
	Width	130±2mm(5.12inch)
	Height	155±2mm6.10inch)
	Total Height	T14:167±2mm(6.57inch) T6:180±2mm(7.09inch)
Approx. Weight		11kg(24.2lbs)±4%



Outer dimensions (mm)

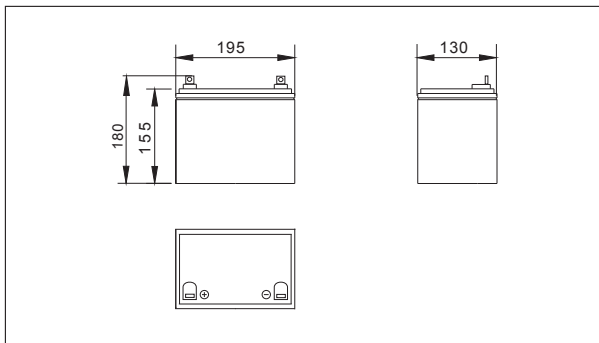

Terminal Type (mm)

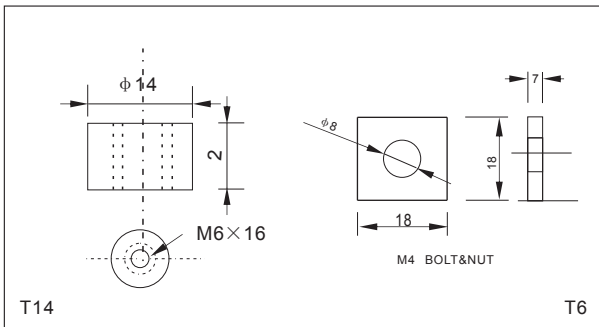

Characteristics

Capacity (25°C)	10HR(10.8V)	33Ah
	3HR(10.8V)	25.5Ah
	1HR(10.5V)	19Ah
Terminal type		T14/T6
Internal resistance (Fully charged,25°C)		Approx.9m Ω
Capacity affected by temperature (10HR)	40°C	102%
	25°C	100%
	0°C	85%
	-15°C	65%
Self-discharge (25°C)	3 months	Remaining Capacity:91%
	6 months	Remaining Capacity:82%
	12 months	Remaining Capacity:65%
Nominal operating temperature		25°C ±3°C(77°F ±5°F)
Operating temperature range	Discharge	-15°C~50°C(5°F~122°F)
	Charge	-10°C~50°C(14°F~122°F)
	Storage	-20°C~50°C(-4°F~122°F)
Float charging voltage(25°C)		13.50 to 13.80V Temperature compensation: -18mV/°C
Cyclic charging voltage(25°C)		14.50 to 15.00V Temperature compensation: -30mV/°C
Maximum charging current		9.9A
Maximum discharge current		330A(5 sec.)
Designed floating life(20°C)		10years

Construction

Component	Positive plate	Negative plate	Container	Cover	Separator	Electrolyte	Safety valve	Terminal
Raw material	Lead dioxide	Lead	ABS	ABS	AGM	Sulfuric acid	Rubber	Copper / lead

Constant Current Discharge Characteristics Unit:A(25°C,77°F)

F.V/Time	10min	15min	30min	60min	2h	3h	4h	5h	8h	10h	20h
9.60V	74.1	57.1	34.2	21.0	12.4	8.95	7.14	6.10	4.20	3.46	1.83
9.90V	71.9	55.7	33.5	20.7	12.4	8.89	7.10	6.07	4.17	3.45	1.83
10.2V	68.9	53.7	32.5	20.2	12.2	8.83	7.05	6.03	4.14	3.44	1.83
10.5V	66.0	51.9	31.7	19.5	12.1	8.77	7.00	5.98	4.11	3.42	1.81
10.8V	62.3	49.1	30.5	18.9	11.8	8.51	6.79	5.80	3.99	3.40	1.80

Constant Power Discharge Characteristics Unit:W(25°C,77°F)

F.V/Time	10min	15min	30min	60min	2h	3h	4h	5h	8h	10h	20h
9.60V	800	627	383	240	144	105	84.0	72.1	49.9	41.3	22.0
9.90V	776	612	376	236	143	105	83.5	71.7	49.6	41.2	22.0
10.2V	744	590	364	230	142	104	82.9	71.2	49.2	41.1	21.9
10.5V	712	569	355	223	140	103	82.4	70.7	48.9	40.9	21.8
10.8V	672	539	342	216	136	100	79.9	68.6	47.4	40.6	21.6

Note: The above characteristics data can be obtained within three charge or discharge cycles.

Euroglobe EGC33-12

Discharge characteristics(25°C)

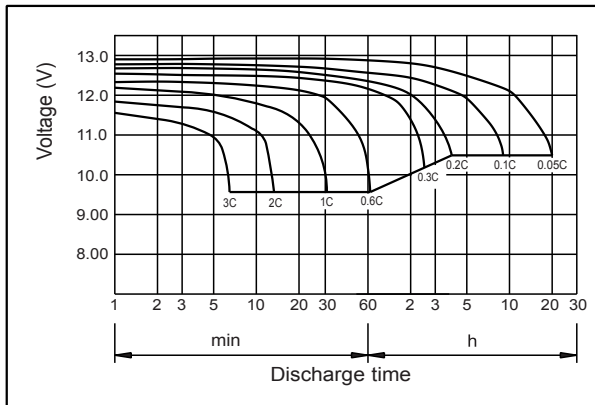

Charging characteristics (25°C)

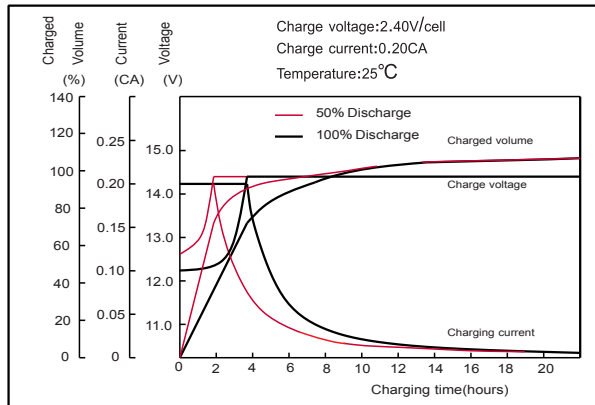

Temperature effects on Capacity

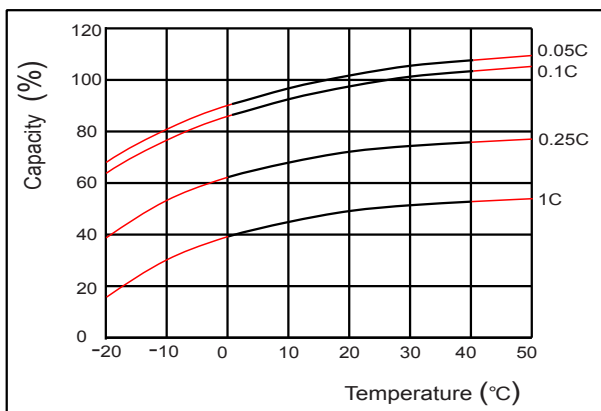

Self-discharge characteristics

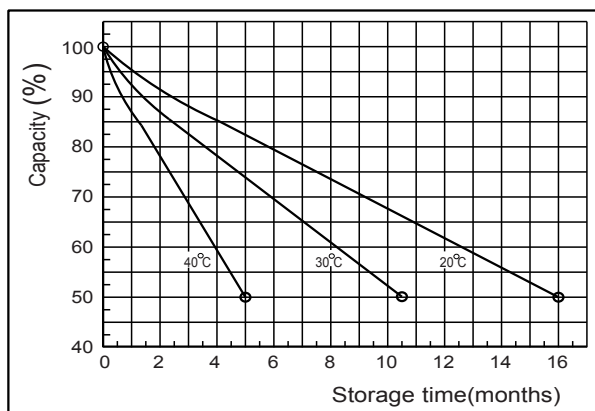

Floating life on Temperature

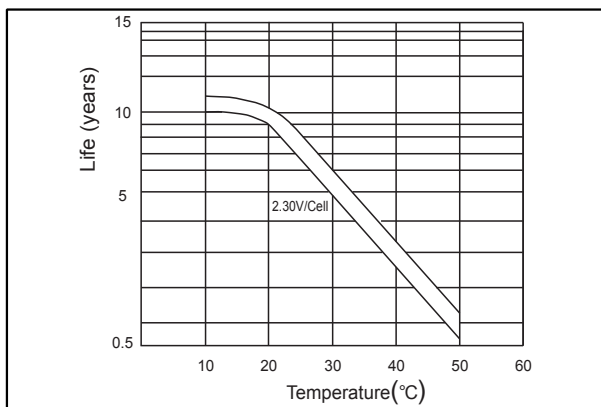

Cycle life on D.O.D (25°C)

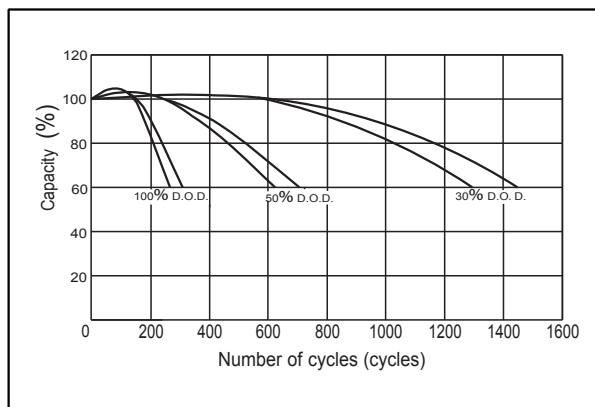

The relationship for OCV and Capacity (25°C)

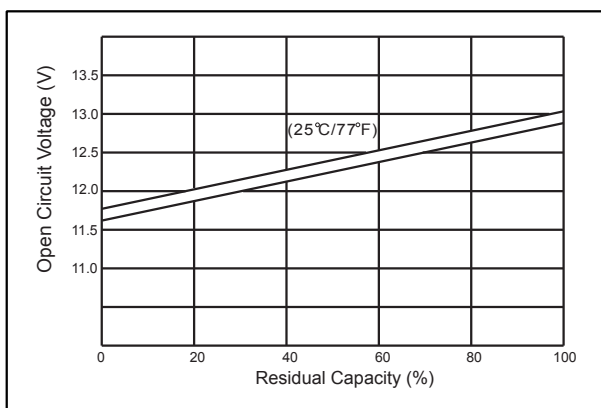

The relationship for Charging voltage and Temperature

